



## >>>>>>>> CAUTION <<<<<<<<<

PLEASE READ BEFORE CONNECTING ELECTRONIC DEVICES TO YOUR JDV!

Caution must be used when connecting electronic equipment to the JDV Mk3. The JDV Mk3 bridges all electronic equipment connected to it so faulty wiring or incorrect grounding of any of the equipment may cause a shock hazard to be present and/or damage to the JDV or other connected equipment. Because grounding schemes differ between manufacturers, it is important to check for correct polarity, in particular with older amplifiers using 2-prong ungrounded A/C cords. If the polarity is reversed on an ungrounded amplifier there may be a potential of 120V present between the amp chassis and ground. Radial Engineering takes no responsibility for this or how the JDV is connected or used. It is the users full responsibility to ensure that proper electrical polarity is maintained on all equipment connected to the JDV and that proper building electrical codes have been followed wherever the JDV is being used.

To reduce opportunity for shock hazard or damage to the JDV or connected equipment, plug the 1/4" connectors into the amplifiers first and then to the JDV. This is especially important when using old amplifiers that do not have 3-prong plugs as the possibility exists to touch the chassis ground with the connector plug tip when the plug is inserted into the jack.

**Cautions for amplifiers with ungrounded 2-prong A/C cords:** Before connecting the JDV to an ungrounded amplifier, power the amp up and listen to the residual hum. If the amp has a two-position ground polarity reverse switch, set the switch in the position that produces the least residual hum from the speakers. If there is no polarity switch, reverse the A/C plug at the outlet to find the least residual hum.

**To ensure an ungrounded amplifier does not present a shock hazard:** Test for voltage potential by connecting a voltmeter between the amplifier chassis and the JDV chassis. If voltage is present, reverse the amplifier's A/C supply polarity and test again.

Note that due to this potential problem, damage to the JDV or other connected equipment caused by improper A/C polarity is not covered under warranty.



Radial Engineering - 1638 Kebet Way, Port Coquitlam BC V3C 5W9  
tel: 604-942-1001 · fax: 604-942-1010 email: info@radialeng.com

Radial Engineering is a division of JP Cabletek Electronics Ltd.

www.radialeng.com



## Radial JDV Mk3 Direct Box



## Owner's manual



Radial Engineering  
1638 Kebet Way, Port Coquitlam BC V3C 5W9  
tel: 604-942-1001 · fax: 604-942-1010

email: info@radialeng.com web: www.radialeng.com

# Radial JDV Mk3 Direct Box

Table of Contents:	Page(s)
Design Concept .....	1
The Magic Behind Great Sound .....	2
What Is a Direct Box Anyway?.....	2
Instrument and Amp Matching.....	3
Control Panel .....	4 ~ 5
Connector Panel .....	5 ~ 6
Balanced Output Panel .....	6
Powering Up .....	7
Setups.....	9 ~ 12
Questions & Answers.....	13 ~ 15
Specifications and Block Diagram .....	16
Warranty and Safety Information .....	back cover

## Introduction

It is with great pleasure that we welcome you to our extended family of Radial direct box owners. We are extremely proud of the Radial JDV Mk3 and are confident that you will find this device to sound great, be fun to use and above all, be a useful tool in advancing your music.

The new Radial JDV Mk3 features the same highly praised Class-A audio circuit that was in the original JDV with several improvements in areas such as lower noise, higher rail voltage and subsequent dynamic range. You will also notice major changes with respect to input and output signal management.

As there are many interesting features that are not found on any other direct box, we highly recommend reading this manual before you start using your new JDV. By doing so you will gain a full understanding of the philosophy behind the product design and enjoy better all-round results.

Enjoy!

For more information, questions or comments, please contact Radial Engineering at the address below or email: [info@radialeng.com](mailto:info@radialeng.com)



**PLEASE READ CAUTION  
ON BACK COVER**

# www.radialeng.com

## RADIAL LIMITED THREE YEAR WARRANTY

Radial Engineering - a division of JP Cabletek Electronics Ltd. ("Radial") warrants this product to be free from defects in material and workmanship to the original owner and will remedy any such defects free of charge according to the terms of this warranty. Radial will repair or replace (at its option) any defective component(s) of this product (excluding finish and wear and tear on components under normal use) for a period of three (3) years from the original date of purchase. In the event that a particular product is no longer available, Radial reserves the right to replace the product with a similar product of equal or greater value. To make a request or claim under this limited warranty, the product must be returned prepaid in the original shipping container (or equivalent) to Radial or to an authorized Radial repair centre and you must assume the risk of loss or damage. A copy of the original invoice showing date of purchase and the dealer name must accompany any request for work to be performed under this limited warranty. This limited warranty shall not apply if the product has been damaged due to abuse, misuse, misapplication, accident or as a result of service or modification by any other than an authorized Radial repair centre.

THERE ARE NO EXPRESSED WARRANTIES OTHER THAN THOSE ON THE FACE HEREOF AND DESCRIBED ABOVE. NO WARRANTIES WHETHER EXPRESSED OR IMPLIED, INCLUDING BUT NOT LIMITED TO, ANY IMPLIED WARRANTIES OF MERCHANTABILITY OR FITNESS FOR A PARTICULAR PURPOSE SHALL EXTEND BEYOND THE RESPECTIVE WARRANTY PERIOD DESCRIBED ABOVE OF THREE YEARS.

RADIAL SHALL NOT BE RESPONSIBLE OR LIABLE FOR ANY SPECIAL OR INCIDENTAL OR CONSEQUENTIAL DAMAGES OR LOSS ARISING FROM THE USE OF THIS PRODUCT. THIS WARRANTY GIVES YOU SPECIFIC LEGAL RIGHTS, AND YOU MAY ALSO HAVE OTHER RIGHTS, WHICH MAY VARY, FROM STATE/PROVINCE TO STATE/PROVINCE.

**JDV Mk3 Specifications**

Frequency Response: Residual Noise: Distortion (20Hz ~ 20kHz): Phase Deviation: Intermodulation Distortion: Input Impedance: Output Impedance: Input Pad (speaker): Output Pad:	10Hz ~ 30kHz (+/-1dB) -93dB @ 1V-RMS < 0.015% @ 1V-RMS (1.2kΩ load) < 0.5% @ 5V-RMS (without load) < 5° @ 100Hz 0.07% (DIN standard) 10kΩ ~ 3.9mΩ 600 Ω -30dB -15dB Custom 30Volt supply
Power requirement:	Custom 30Volt supply

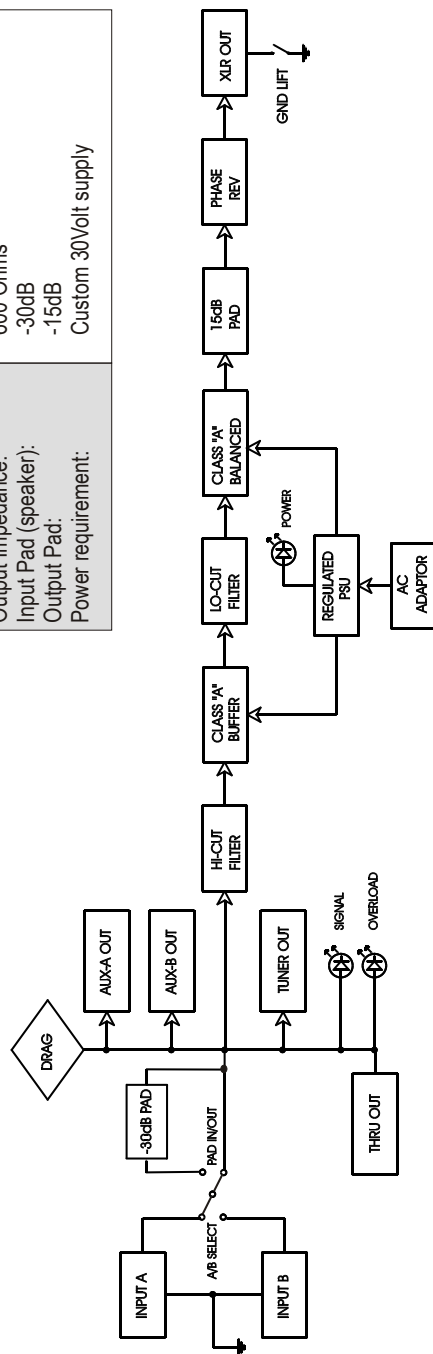
**JDV Mk3 Block Diagram**

## JDV Mk3 DirectBox

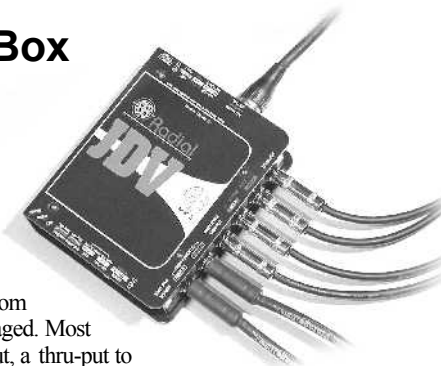

### Design Concept

If you think about it, a direct box is actually a central distribution hub from which the instrument signal is managed. Most DI's simply offer an instrument input, a thru-put to the musician's amplifier and then an output for the mixing console.

The Radial JDV Mk3 takes this concept to a completely new level by providing the musician and engineer with greater flexibility than ever before and does so without any signal degradation whatsoever. The concept is simple: We have broken down the signal path into three zones:

- (1) Instruments, (2) Musician's setup, (3) Engineer's setup.

### Radial JDV Mk3 Zoned Concept

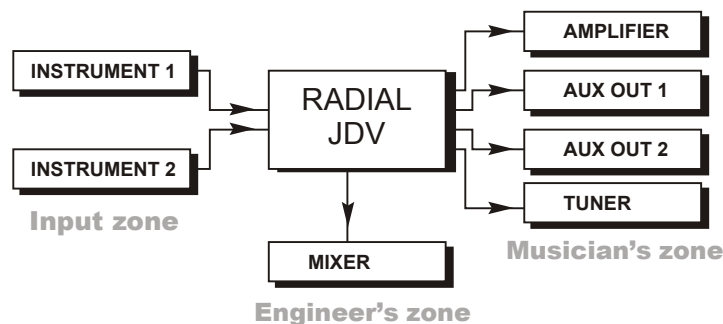

Each 'zone' features expanded functionality: Dual inputs allow two instruments to be selected without having to reconnect. By offering several instrument thru-puts, the musician can now work inside his own 'creative world' giving him greater freedom to create new sounds and inspired results. These include a standard thru-put for a traditional amplifier, two unity-gain auxiliary outputs to drive a stereo rig, an effect device or simply more amps. A designated tuner output allows constant frequency monitoring while being outside the primary audio signal chain. For the engineer, a standard balanced XLR output provides the dry instrument signal to track.

One may ask: "This seems so easy and natural, I wonder why no one has ever done this before?" Truth is that although it may look easy on paper, the challenge is retaining the signal integrity without degradation. The JDV does this with virtually zero harmonic distortion, phase distortion or inter-modulation distortion. To make matters even more interesting, matching the buffered outputs to the thru-put presents yet another challenge. But what is life without challenges?

## The Magic Behind Great Sound

With the advent of 24bit/96kHz digital recording, expanding dynamic headroom while lowering the noise floor has become the 'holy grail' of analogue circuit design.

The Radial JDV begins with a true Class-A design for audiophile quality. Class-A circuits are preferred over more common push-pull designs (Class A-B) as they do not introduce harsh zero-cross distortion. Open the JDV and you will see big, high-voltage discrete components. These are used because they simply sound better! For example, larger capacitors are able to store more energy than smaller ones. This means that the audio signal does not starve when pushed to the limits.

But that is not all. The Radial JDV Mk3 is actually a feed-forward design. This means that unlike traditional circuits that use a feedback loop to stabilize the signal path, the JDV circuit looks more like a tube design which by all accounts is nuts! The result however is stunning! Run a square wave through the JDV and you get perfectly sharp edges without overshoot or ringing.

To further enhance headroom, the JDV employs an unprecedented 30-volt internal rail voltage for exceptional dynamic signal handling. High output signals are handled with ease and since it is virtually impossible to overload the JDV, phase, harmonic and inter-modulation distortions are virtually eliminated. **One should note that the Radial JDV is a unity gain device.** This means that whatever you put in you get out. In fact, the JDV has so much headroom the PAD is located at the output so that it will not overload your mixer.

To elevate sound quality yet another notch, we have added Drag™ control; an innovation that we developed while creating the popular Radial JD7 Injector that essentially recreates the natural tone that is lost when driving buffered outputs to several amplifiers (more on this later).

At the end of the day, what sets Radial products apart from all others is our unyielding commitment to quality and our never ending quest to make our products innovative, and musical.

Ultimately, the magic to great sound comes from the added care during the design process, better quality parts and a full understanding of how musicians and engineers work so that the most can be derived. We do everything we can to make sure that what you put in, you get out.

Nothing added, nothing lost.

## What Is a Direct Box Anyway?

Whether in live or studio conditions, connecting an instrument to a mixer requires matching the high-impedance (high-Z 1/4" guitar jack) of the instrument to a balanced low-impedance (low-Z XLR jack) system. This is the primary task of the direct box. Proper impedance matching will provide a wider frequency response, improved dynamics and in most cases significantly less noise.

It is important to note that the output of the direct box is designed to work alongside microphones. Once the instrument signal has been converted to a balanced low-Z signal (think low resistance), it must drive long cables without appreciable noise. Concert snake systems employ splitting transformers to bridge the signal to several destinations such as the front of house (FOH) mixing console, the monitor mixing console, and sometimes a broadcast or recording truck. These 'bridging' transformers are designed to work at mic level. Since DI's need to work within this same environment, the output signal is akin to a 600-Ohm mic level.

Thus the output of a direct box should be connected to a mic input such as found on mixing consoles or mic preamps. The better the pre-amp, the better the results.

### *Why is the speaker pad switch recessed and difficult to get to?*

This is a think before action precaution. This is the most dangerous feature on the JDV. If one connects a speaker output directly to the JDV without a load, there is a good chance that they will blow the input. By making sure that getting into this function is difficult, we figure that the user will be aware of what he is doing and be less prone to make a mistake.

### *I am not getting much level. What could be wrong?*

Check the recessed -30dB speaker pad switch. If this is pushed in, the input level will be way down. This is usually the offender because it is hard to see. Also, check the -15dB output pad to make sure it is not depressed.

### *I am getting too much level, can I use the line level input on my mixer?*

Yes. The JDV, being a unity gain device, is able to produce line level output signals if driven hard.

### *The sound seems a little muffled in the high-end?*

If the **Vary-Z** is engaged and the Drag control is completely counter-clockwise, the sound can be muffled as you are dropping the input impedance well below normal. Also check to make sure the lo-pass filter is not on.

### *Can I use the Tuner out to drive another amp or effect device?*

Yes but the quality of this output will be more along the lines of regular direct boxes. The **TUNER OUT** signal is guitar level and is perfectly fine for effects and having fun. Of course its primary function is to keep you tuned without allowing the tuner circuit to get in the way of the sound.

## Control Panel

All input controls and visual monitoring are located on the JDV's input panel. No connectors are on this panel so clear access to the controls and monitoring is provided without cables being in the way.

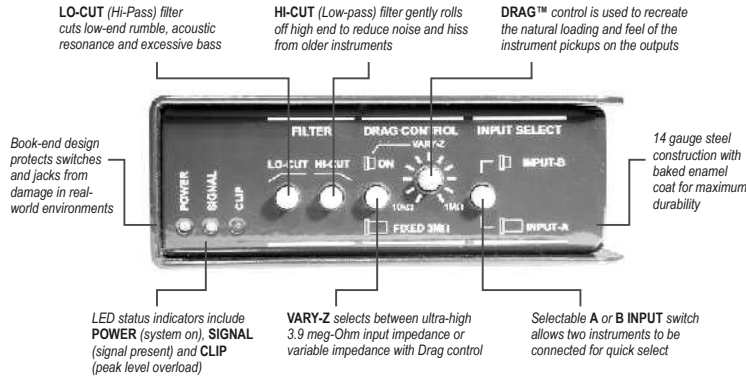

### LED Status Indicators

LED status indicators for **POWER** on, **SIGNAL** presence and **CLIP** peak overload. Normally, the green power LED should be on as soon as the JDV power supply is connected. The yellow signal presence LED will flash on and off following the music program while the red overload LED will light up should the input signal ever exceed the normal operating level.

### LO-CUT and HI-CUT Filters

The JDV is outfitted with two filters: The **LO-CUT** (Hi-Pass filter - cuts low frequencies thus allows the allows high frequencies to pass) is set at  $-3\text{dB}@175\text{Hz}$  for a gentle, natural sounding roll-off. Hi-Pass filtering is used to lessen low-frequency 'mud' that can sometimes cause bass to lose definition. It is also extremely effective at reducing resonance or rumble that is common with acoustic guitars during a live performance.

The **HI-CUT** (Low-Pass filter - cuts high frequencies and allows low frequencies to pass) is set at  $-3\text{dB}@8\text{kHz}$  providing a simple solution to reducing hiss and noise from older equipment such as noisy keyboards, older active acoustic guitars or when using the direct out from noisy amplifiers.

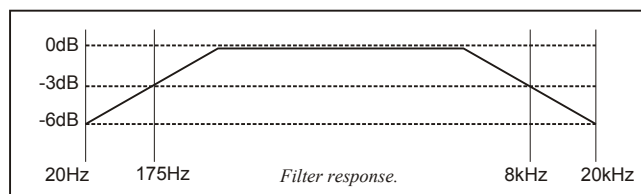

## Questions and Answers

### What is a direct box anyway?

A direct box is an impedance matching and signal-balancing device. DI's convert hi-impedance instrument signals to mic-level balanced lines for interface with pro-audio equipment such as mixing consoles. A good direct box will ensure proper electrical signals are maintained throughout the signal chain and allow long cable runs without added noise. A good DI box is just as important as a good microphone.

### What is the difference between active and passive direct boxes?

Active direct boxes require power such as a separate power supply, 48V phantom power, or a battery to activate their circuits while passive direct boxes convert the signal from high-Z to low-Z using only a transformer. Passive DI's do not require a power supply to work.

### I heard active direct boxes are better?

This can be thought in terms of a dynamic mic compared to a condenser mic. There are good dynamic mics and there are good condenser mics. A good passive direct box depends entirely on the transformer that is being used. For instance, the Radial JDI uses the world's finest transformer, a Jensen. These DI's sound fabulous! In fact way better than most active direct boxes!

### If the JDI is so good, why should one buy the JDV over the JDI?

It comes down to the application. For keyboards, and simple live set-ups, the JDI is fantastic. No power supply, no batteries to go dead. You just plug it in and it sounds great. The JDV on the other hand will give you more reach. You will enjoy more detail or as Khaliq Glover (Engineer for Marcus Miller and Herbie Hancock) said: "the JDV is almost holographic compared to the single dimension of most DI's."

### Can I power the JDV with the 48V phantom on my console?

No. Typical 48V phantom power only has 5 milliamps of available current. The JDV requires much more current than this to drive its 30 Volt rails. Phantom power is simply unable to do the job.

### Why would I buy the JDV over other active direct boxes?

Sound quality. There is nothing on the planet that will do a better job than the JDV. It is designed from the ground up to be sonically pure, exceptionally dynamic, and totally transparent. The combination feed-forward design, class-A circuit and 30 volt internal rails combine to put the JDV in a class of its own.

### Why is Class-A considered best?

Class-A circuits do not employ multiple gain stages to achieve greater efficiency. They are pure gain stages that have and continue to be the choice for audiophiles and purists. Although more efficient, Class-B or AB circuits suffer a problem called zero-cross distortion that Class-A devices do not. In the JDV, we are not concerned about power-per-watt output, we are only concerned about getting the best possible sound. We go a step further in employing a unique feed-forward design.

### What is a feed-forward design?

The 'easy guide' to circuit design always includes a feedback loop in the circuit to stabilize the circuit. The JDV does not take the easy way out; there is no feedback loop. The JDV circuit is akin to a pure tube circuit design. The result is razor sharp precision without overshoot, ringing or rounded-off wave generation. This things is almost alive!

### -30dB Parallel Speaker Pad

Sometimes, it may be desirable to tap the signal from the speaker cabinet to get the sound of the instrument after the amplifier (post effect). The JDV is equipped to do so by inserting a -30dB input pad into the circuit..

Using a speaker-tapped signal can be fun however it should be noted that the signal from the guitar amp is designed to drive 12" and 15" instrument speakers which mask high frequencies (no tweeters). Because of the extreme fidelity of the JDV, it is possible that residual noise content from the amp and the speaker 'hang-over' effect will be audible. Try using the JDV's high-frequency roll-off (**HI-CUT** filter) or adjust EQ to suit.

To activate the -30dB pad, depress the recessed 'PAD-30dB' switch using a pen or small screwdriver, then connect the signal from the speaker cabinet or the amplifier's second speaker output using a regular speaker cable. **Failure to connect a speaker or load box in parallel to the JDV may cause severe damage to the JDV and/or the amplifier which would not be covered under warranty.**

**IMPORTANT: The Radial JDV is NOT a load box** and can not handle the power coming out of an amplifier head on its own. A speaker or properly matched load box must be connected to the amp before connecting the JDV.

## Balanced Output Panel

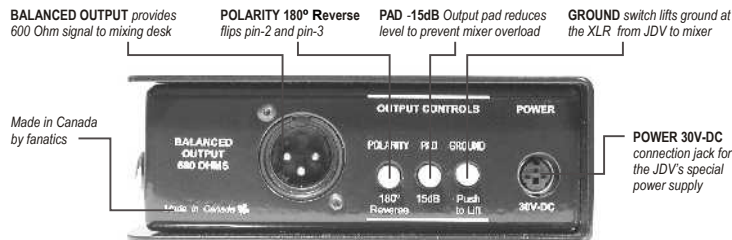

### BALANCED OUTPUT

600 Ohm mic level XLR-M output connector wired to the AES (pin -2 hot) standard connects to mixer or mic pre-amp input.

### POLARITY 180° Reverse

Switches XLR pin-2 (normally hot) with pin-3, useful when interfacing with older equipment wired with pin-3 hot. Also a useful creative tool in the studio. When mic'ing an amplifier and recording a direct signal, reversing the polarity can lead to some very interesting and fun effects - try it!

### GROUND Lift

Switch lifts the ground path from the JDV to the mixer. When depressed, the JDV ground is solely connected to the guitar amp and/or aux outputs.

### -15dB Pad

As the JDV is a unity-gain device with an exceptionally high internal rail voltage, a powerful input signal will produce a powerful output level. As the JDV's output can often exceed the input capacity of many mixing consoles, a -15dB output pad is provided to ensure it does not overload the input.

In this set-up, if ground hum is encountered, lift the ground to the mixer with the ground lift switch. The JDV will now derive its safety ground from the amp. For safety, make sure you only use amplifiers with proper 3-pin U-grounds!

Reversing polarity can have dramatic effects on stage if the bass is also in the stage monitors. Polarity reverse only affects the XLR output. Try in-phase first, then reversing polarity. It may sound better or widen the players sweet spot.

Activating the **LO-CUT** (High-Pass) filter can help reduce low-end rumble and help clean up the mud which often is difficult to manage in large PA systems.

### Acoustic guitar set-up

One of the most important features of the JDV is its ability to handle extreme transients without overloading. Guitar players often drive the pre-amps on their acoustic guitars above the nominal 0dB level and then push it further by increasing treble or bass. What few realize is that a mere 3dB increase is actually increasing the headroom demand by twice the power at that frequency. The JDV's 30Volt internal rail system is able to handle these demands without a whimper making it a great choice for acoustic guitars on live stages.

Use the bass guitar set-up described previously. Use of the **LO-CUT** (Hi-Pass) is recommended to reduce rumble. Test for best polarity setting as above.

### Keyboards

The JDV is perfectly fine for use with electronic keyboards. In fact, the JDV's sonic performance is superior to what most of these are able to generate. Where the JDV will shine will be on very dynamic sounds such as grand-piano samplers where the frequency response is very wide, harmonics are rich and amplitude variations extreme. Use the same setup as described in Set-up 1 or 2, depending on whether or not an instrument amp is used.

### Driving more than one amp

One of the more exciting aspects of the JDV Mk3 is its ability to drive several amplifiers or devices at the same time. This expanded functionality provides freedom to build new sounds that spur the creative process.

The Radial JDV makes this possible and easy by providing two active outputs designated Aux-A and Aux-B. These are transformerless Class-A feed-forward outputs that have been designed to reproduce the instrument without adding artifact. At this stage, it is important to understand how Drag™ control works and when it would be appropriate to use it (see 'Drag Control' on page 5).

The most common application would be driving a stereo amplifier rig.

*Important Note: 3-pin U-ground plugs did not exist in the '50's and early '60's and, as great as they sound, the amplifiers of those days were never designed to be combined together as we often do now. You may find using un-grounded equipment a problem because of noise from hum and buzz. For more advanced or difficult set-ups, check out the Radial JD7 Injector. It is equipped with isolation transformers as a means to solve some of these electrical challenges.*

Connect the JDV's two auxiliary outputs to the stereo rig or two amps. As these outputs are not transformer isolated, both amps should have grounded A/C cords in electrical phase and be connected to the same power bar as the JDV. This will reduce possibility of electrical shocks and noise caused by ground loops. For safety, please observe correct grounding, check for shock potential with a voltmeter and/or consult with a trained technician.

scope of this manual, we recommend that users take the time to access the wealth of information available on this subject on the web, at the library or by consulting with recording engineers or colleagues. The following are some pointers to get you started.

### Ground Loops

When connecting several pieces of equipment together, a common problem is ground hum and noise caused by what is commonly known as ground loops. These are usually caused by electrical phase inversions, by common-mode noise or voltage differential between equipment.

The JDV is equipped with a ground lift switch that lifts the ground connection from the JDV to the mixer at the balanced XLR output. The JDV employs a floating ground scheme and as such must be grounded at either the input or the output.

For instance, if you are using the JDV with an acoustic guitar and connecting directly to the mixer without using any of the 1/4" output connectors, the ground lift should be in the out position so that a safety ground to the mixer is galvanized. If on the other hand you are using the 1/4" outputs, the ground lift can be 'lifted' (depress the switch) as the JDV will now be grounded in two places.

A common solution to reduce ground noise is to connect all of the audio equipment to the same electrical phase. This is easiest accomplished by using a power bar and a single power outlet. On large stages, touring professionals have their own 'distros' or power distribution systems that are pre-configured to this end. We suggest consulting an electrician and a trained audio technician should you be in a position to rewire your studio.

### Induced Noise

Electro-magnetic induction (EMI) is caused by the magnetic field from one electrical circuit polluting the field of another. Every copper wire, be it low-level signal or high power voltage, will emit a magnetic field. These wires are also subject to induced noise from adjacent magnetic fields. The more power going through the wire, the larger the electro-magnetic field. For instance, power cables emit a large magnetic field while signal levels do not. In fact, signal level conductors are either shielded or split into balanced twisted pair configurations as a means to keep unwanted noise out. Good quality cable is important.

By keeping audio cables away from power cables, you will immediately reduce the noise floor. If you must cross these, cross them at 90° if at all possible so that the interaction of their magnetic fields is kept to a minimum.

The Radial JDV comes equipped with a separate DC supply. As commonly known, power supplies emit magnetic fields, which in turn can cause noise in audio systems. The advantage of an external supply is less noise inside the JDV's metal shell. To further reduce magnetic induction, the JDV power supply should be kept away from any signal carrying cables and equipment.

### A Note About Safety and Shock Hazards

When connecting several pieces of equipment together, it is very important to ensure that proper electrical wiring be maintained. This is most important when using older equipment in older homes or venues where electrical safety standards may not have been upgraded to today's standards. Before connecting equipment together, always ensure all amplifiers or equipment being used are connected to a proper electrical system and ensure that all equipment is grounded via the A/C cord's 3<sup>rd</sup> prong (U-ground). Failing to do so could cause severe damage to your equipment and/or increased possibility of electric shock.

## Typical Setups

### Acoustic guitar without amplifier

The direct connection is the most basic set-up, most often employed in live stage or studio situations where the musician does not have his own amplifier, and relies on monitors to hear their instrument.

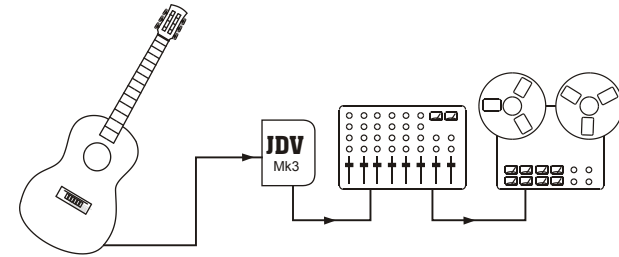

In this set-up, the **VARY-Z** switch is normally in the OUT position, as active instruments will not be affected. For acoustic guitars, we suggest depressing the **LO-CUT** (High-Pass) filter switch. This gentle roll off will reduce acoustic resonance and opportunity for low-frequency run-away feedback without affecting the tone. The **HI-CUT** (Low-Pass) filter would only be engaged if the instrument is generating exceptional high-frequency noise or hiss. The ground switch should be in the OUT position to ensure proper safety grounding to the mixer.

### Electric guitar in the studio without amplifier

This same connection as shown above is used in the studio for direct recording of basses and clean guitar tracks. The difference here being that the instrument may be passive like a traditional Fender Precision Bass. As such, you may want to engage the **DRAG** control to recreate the natural loading of the instrument.

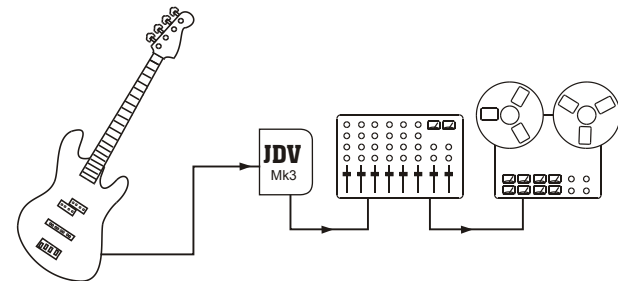

Start by turning the **DRAG** fully clockwise and depress the **VARY-Z** switch to drop the input impedance to 1 meg-Ohm. Now turn the control counter-clockwise until the sound 'feels' right. This subtle effect will depend on the output level of the pick-ups and creative decision making of the engineer. 12 o'clock is an average single coil pick-up to a regular amplifier.

### Speaker box parallel connection

**⚠ Be sure to read the caution on page 6 re: -30dB Parallel Speaker Pad.**

Careful... this fun feature can also get you into trouble. We recessed the switch to make the use of this function deliberate and protect the JDV's input from being damaged through accidental (mis)use.

Sometimes, you may wish to get the sound of the bass or guitar after it has gone through the amplifier. The JDV allows you to tap the sound off the speaker cabinet to achieve this. This can be a useful solution when mic'ing the amplifier is impractical. It can also lead to some great sounds when combining mic'ed and direct signals.

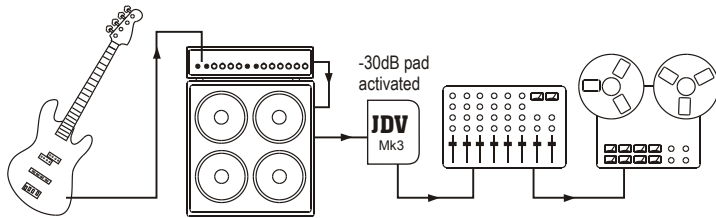

Using a regular speaker cable, connect the signal from the parallel speaker jack to input-A on the JDV. Use a pen or small screwdriver to activate the recessed -30dB pad and connect as shown above. The Drag control will have no effect. Note that most amplifiers have a lot of self-noise. Try using the lo-pass filter to roll off some of the high frequency noise. Have fun!

## Traditional live set-ups

### Bass guitar setup

A common use for a direct box is on stage with a bass guitar. This same set-up is also often used in the studio where the musician's amp may also be mic'ed alongside the direct feed and then mixed together by the engineer.

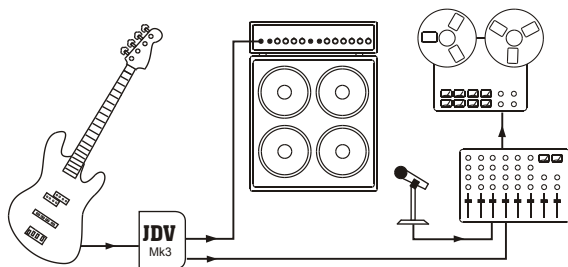

The signal goes from the instrument to the JDV, where the thru-put is connected to the musician's amp and the XLR output is connected to the mixer. To start, we recommend all switches be in the out position. The JDV thru-put is a passive output that passes the bass signal directly to the amplifier. With the **Vary-Z** switch in the out position, we will present the highest impedance to the instrument and therefore the least possible loading. (See discussion on loading in page 3 of this manual). This will provide the most natural sound to an instrument amplifier.

## Powering Up

Inside the JDV packing box you will find the JDV, the power supply and the manual. The connection on the power supply is a 3-pin mini-DIN. You should not attempt to use any other supply other than the one that comes with the unit.

As we expect the Radial JDV to be used in 'real-world' conditions where it may be dropped, kicked and stacked, the JDV has been outfitted with several abuse resistive features including: A 'bookend' design that creates a protective zone around the switches, controls and jacks, a



*Use only the JDV's supplied power adapter.*



*The JDV's strain relief in action.*

full bottom non-slip rubber pad that provides mechanical and electrical isolation while ensuring the JDV will stay put, and an innovative cable-locking strain relief.

To use the strain relief, simply loosen the nut with a hex wrench (Allen key), pass the cable through the clamp and tighten. Using the strain relief prevents accidental un-plugging... a good idea especially on action-packed stages!

### Turning the Radial JDV On

As soon as you connect the power supply to the JDV, it is on. A green LED on the control panel will light up at this time. Leaving the JDV connected will not harm the unit. In fact the JDV, like all other electronic audio equipment, will sound better once it has reached its stable working temperature. This should take no more than 5 minutes.

Before you start, make sure all levels on your amp and mixer are turned off. Connecting the JDV in a traditional fashion is simply a matter of connecting the instrument to the input, the thru-put to the instrument amplifier and the XLR output to the mixer. Complete connection options are discussed further in this manual.

We suggest you start by leaving all switches in the OUT position and use input-A to connect the guitar. Now slowly bring up your amp level and then your mixer level. Signal should be present at both. If you encounter buzz, try lifting the ground on the JDV. You should now be set to go.

### Dealing With Ground Hum and Noise

In developing the Radial JDV Mk3, we took painstaking measures to ensure noise was reduced to an absolute minimum so that the JDV would be ready for the most demanding analogue and digital recording environments. To get the most out of your JDV, it is important to understand how noise can degrade the signal and how some simple preventative measures can ensure maximum signal integrity.

Noise, the curse of any audio system, can be greatly reduced by following some simple rules of thumb using basic electrical principals. As this is beyond the

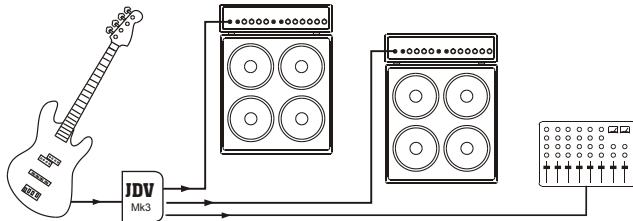

If you are using a passive instrument like an old Precision or Jazz bass, a Strat or a Les Paul, we recommend that you depress the **Vary-Z** switch and use the **DRAG** control to dial-in just the right amount of natural sounding pickup loading. Start at 12 o'clock and use your ears!

Remember that any post JDV effect you introduce into the signal chain will only be heard coming from your stereo rig. The original 'dry' sound from the instrument will still appear at the JDV's XLR output allowing the engineer to either record a dry track or mix the dry track with the mic'd amps on stage.

### Re-amping using the JDV with a Radial JDI

A common trick used in recording today is to record a dry guitar track and then send the recorded track back into the guitar amplifier. This allows the guitarist to listen to various amplifiers and effects while in the control room.

A great solution to re-amplifying over extremely long distances can be achieved by combining the JDV and the Radial JDI wired backwards. This may sound strange, but because the JDI is a passive direct box, it employs an impedance matching transformer that can either be used to transform the signal from high-Z to low-Z (traditional DI) or from low-Z to high-Z for use when sending a balanced signal back to a high impedance input such as on a guitar amplifier.

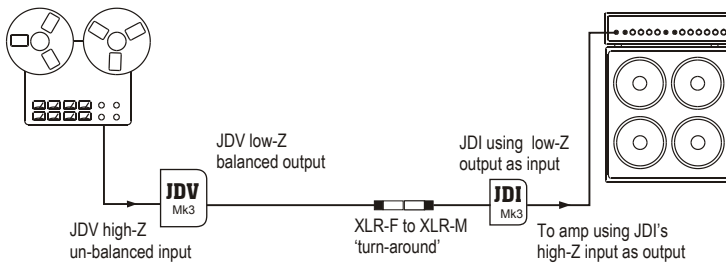

Record a dry track using one of the JDV setups previously discussed, then send the recorded track into one of the JDV's high-Z unbalanced inputs (A or B). Connect the JDV's low-Z balanced output to the balanced **input** of the Radial JDI, and use the high-Z **input** of the JDI to feed the amplifier.

### DRAG™ Control

'Drag' was developed during the R&D phase of the Radial's JD7 Injector guitar signal distribution amplifier/router. After many listening tests we found that the JD7's output was too perfect. It did not sound right. The reason was simple: a vintage pick-up signal, when passing through a pre-amplifier, becomes active and the natural loading or interaction between the guitar's pick-up and the amplifier's tube input circuitry is lost. Drag control re-introduces the desired loading effect by providing the user with control over impedance and resistance.

The JDV's **DRAG** control is activated by depressing the **VARY-Z** switch. A typical vintage Stratocaster to a Fender Twin relationship can be dialed in at about 10 o'clock. Less Drag (turning the knob clockwise) will open up the sound and result in more high-frequency content. It is important to note that you should use your ears to set the Drag control as every amplifier and every pick-up will be different. The more you play with Drag, the more you will find that it is extremely musical.

### INPUT Selector Switch

To increase functionality, the JDV allows two instruments to be connected via the **A & B** 1/4" input jacks which are located on the instrument control panel. Two guitars or basses are often used during a performance for alternate tuning, different sounds or simply as a spare for a broken string. The JDV allows the musician to quickly select an instrument by simply depressing the instrument **INPUT** select switch, eliminating hassles such as setting the amp on standby or muting the instrument to avoid connection popping.

### Connector Panel

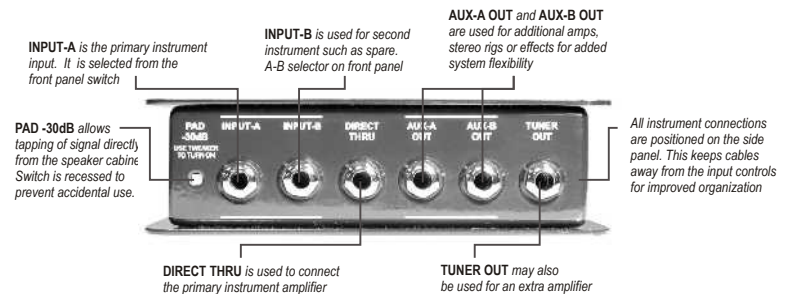

### Amplifier Outputs

Four 1/4" outputs are provided on the JDV to provide the musician or engineer the greatest flexibility for recording or live performance.

**DIRECT THRU** - Used as the primary output to the guitar amplifier.

**AUX-A OUT & AUX-B OUT** - Used to drive additional amps and effect devices.

**TUNER OUTPUT** - Connects to tuner while keeping the tuner out of the audio circuit. Can also be used to drive an additional amplifier.

### *The overload LED never goes on. Why?*

Because the JDV has such a huge internal rail voltage, instruments are typically unable to drive sufficient current into the JDV to cause it to overload. Kinda' like having 12 cylinders on a car. You don't need them until you are racing. Kick 'em in and the extra horsepower makes all of the difference!

### *Can I overload the JDV's input?*

We could only get the JDV input to overload when we drove the output from the line level of a mixer directly into the JDV and turned the volume up high. It is unlikely, under normal use, that you will ever overload the JDV.

### *Can I connect a guitar amp head to the JDV without speakers?*

No. The JDV is not a load box. This means that you must connect the amp to a load 1<sup>st</sup> (like a speaker) and then you can connect the JDV to the load.

### *Can I connect a guitar amp head to the JDV with a load box?*

Yes. However you should be careful to ensure that the load box properly emulates a speaker. Make sure the -30dB pad is engaged and monitor the JDV's input to make sure the overload LED does not go on.

### *What level is the JDV output?*

The JDV is a unity gain device. This means that although it is designed to output a mic level signal, the output can be significantly higher depending on what input is being sent to it. This is why there is an output PAD on the JDV. This allows hot signals to be padded down so that they do not overload the input to mixers or mic level isolation transformers.

### *Why don't you put the power supply inside the JDV?*

Noise. Due to the JDV's abnormally high input impedance, the internal working level of the JDV is extremely low. This means that we must do everything we can to ensure unwanted noise stays out of the JDV circuitry. Power supplies tend to be a major contributor to noise. Keeping the noise outside is a good thing!

### *What are the differences between the old JDV and the new JDV Mk3?*

The original JDV and the new JDV share the same audio circuit topology and philosophy. Both use the same Class-A feed forward designs. The old JDV used a rechargeable battery as a primary supply while the new design does not. We found that although the original JDV worked well, many users were confused about charging the battery and unless you read the manual, you could get some pretty awful distortion or worse yet, you would think the unit was defective.

The Radial JDV Mk3 is the third generation JDV and in developing this box, we set goals in place that included making the unit more user friendly, lowering the self-noise and expanding the dynamic range. All of the good things that were in the original have been maintained or wherever possible improved upon.

Obviously the new JDV has many more features. But that is not all: The new JDV has gone from using SMT (surface mount technology) to the higher capacity and precision of discreet components. In order to expand the headroom, we developed a totally new power supply with a floating ground scheme for less noise, and we got rid of the rechargeable batteries!

### *Why did you not put a knob on the Drag control?*

Originally, the Drag control was supposed to be recessed so that once set, the control would not be touched. However we found that it was so darn musical that people would be adjusting it all the time. Because the JDV will probably live on the floor most of the time, we felt that a knob would stick out and get kicked and broken. So no knob. Kinda' looks weird at first, but you'll get used to it.

## Instrument and Amplifier Matching

One of the most beneficial features of the JDV is its ability to handle a wide range of instrument levels and pick-up configurations. Because of the exceptionally high internal rail voltage, the JDV does not require an input pad except for excessive levels such as parallel speaker connections. (This is detailed later in the manual).

It is important to note that even though the JDV can handle any level, to truly capture the essence and detail of an instrument, a more precise control is required. Thus the reason we have incorporated Drag™ control.

When a guitar is connected to an amplifier, the amplifier and the pick-up will interact. In fact, different cables will also affect the tone. This direct loading is a normal and essential part of what makes a guitar sound the way it does. Lower output pick-ups such as those found on vintage instruments are most affected.

When, for instance, a bass is connected to a regular direct box and then to the amplifier, the pickups are no longer driving the bass alone; the signal is split between the musician's amplifier and the XLR output that is going to the mixer. In live situations, the mixer can be as far as 300 feet away. This means that when using a passive direct box (transformer style) the lowly pick-up must drive the signal all 300 feet while still driving the amplifier. This loading effect can sometimes cause the instrument to sound listless and lack punch.

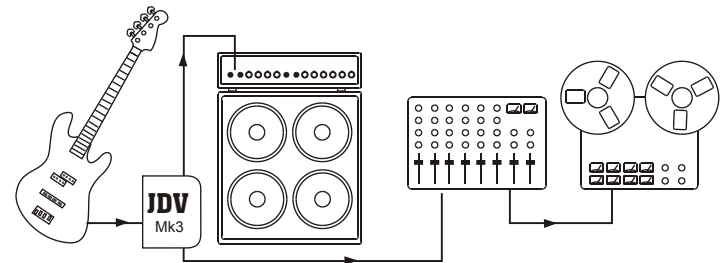

Active direct boxes solve the loading problem by presenting the pick-up with a high input impedance, thus limiting the energy from the pick-up being sent to the direct-box and sending most of the pick-up's energy to the instrument amplifier. The higher the input impedance, the more natural the tone going to the musician's amplifier. Only one problem; the lower the instrument signal to the direct box, the more difficult it is to amplify the signal to a usable level without adding noise, phase distortion and inter-modulation distortion. (Nothing good is ever free!)

Most direct box input impedances range from 10k-Ohms to 1 meg-Ohms while the JDV is outfitted with a very high 3.9 meg-Ohm input impedance. The JDV is able to present this unprecedented input impedance due to the ultra-low noise design and the unique Class-A circuit that can amplify the signal without adding distortion.

The 3.9 meg-Ohm input was chosen to reduce loading and for use with piezo pick-ups such as those typically found on stand-up basses. These are normally in the 3 to 4 meg-Ohm range and thus when used with the JDV provide optimum impedance matching for best tone.